

The development of a hybrid racking panel – appraisal of methods for strength and stiffness calculation.

Kenneth Leitch¹, Dr Robert Hairstans²

ABSTRACT: Throughout the U.K, Timber Platform Frame is increasingly being utilized in the high volume, low cost housing market. Here, the client’s desire for fully detached housing often leads to narrow properties with openings concentrated in the shorter wall. This can cause design considerations since the number of full height wall panels deemed to give resistance to racking forces is reduced. In order to achieve the required racking resistance, remedial measures such as the application of additional sheathing, improvement of the sheathing fixity and even the use of steel portal frames, are often employed. Whilst these measures can be considered structurally effective they can also lead to the over specification of materials resulting in a decrease in overall project efficiency. In order to prevent this, research is currently being carried out at Edinburgh Napier University into the development of a series of racking solutions which are optimized in terms of performance, installation and cost.

This paper considers factors influential to racking strength and stiffness such as the degree of fixity between the sheathing and timber frame, nailing intensity and layout and the degree of overturning restraint. A series of racking tests were carried out and the results are used to assess the accuracy of a simplified plastic model for the prediction of racking strength. The paper also highlights the need for a “stiffness check” in order to ensure that structures do not suffer from excessive deflections. A review of an existing analytical model for predicting panel deflection is undertaken and it is found that the method gives acceptable results when predicting the racking strength of imperforate wall panels with varying degrees of overturning restraint. It is also found that estimating the deflection at the wall head based only on the nail slip of the sheathing fastener and the shear deformation of each sheet leads to an overestimation of wall stiffness performance.

KEYWORDS: UK construction, Timber Platform Frame, Shear wall, Low rise domestic dwelling, racking resistance

1 INTRODUCTION

Current British Standard design practice of timber frame shear walls is based on dated manufacturing principles. Furthermore, the British Standard design method is based on a Permissible Stress methodology and is therefore incompatible with the Limit State design approach adopted by *BS EN 1995-1-1* (Eurocode5/Ec5) (1). A drive towards sustainable construction methods, “zero carbon” homes and the utilisation of off-site construction has lead to an increase in volume of timber platform frame construction (TPF) in the UK. Market forces and end user preferences currently dictates that houses are often designed as fully detached structures, with small footprints, narrow aspect ratios and a high

percentage of openings (large window, patio doors etc). This has lead to reliance on the over specification of materials and/or the use of steel portal frame “goalposts” in order to ensure that the in -plane wall strength (“racking” resistance) is adequate to resist applied wind loading. As a result, the overall efficiency of the structure is reduced.

Presented in this paper are the results from a series of racking tests carried out on full scale stud wall panels. The panels were manufactured using methods and materials concurrent with UK practice and were tested in accordance with *BS EN 594:1996* (2). The test results are used as a basis from which the accuracy of a simplified model for the design of partially anchored wood framed shear walls developed by Källsner and Girhammar (3) is assessed. The implications of these findings on the development of a series of optimized racking solutions are also discussed.

2 Background

Due to the fact that the TPF method has been utilised throughout the world, there is a large amount of

¹ Kenneth Leitch, Edinburgh Napier University, 10 Colinton Road, Edinburgh, EH10 5DT, Scotland. Email: k.leitch@napier.co.uk

² Dr. Robert Hairstans, Edinburgh Napier University, Email: r.hairstans@napier.co.uk

published literature related to the performance of shear walls and to racking behaviour. However, in the UK, research carried out by Griffiths (4) represents the only major investigation specifically focused on UK methods of design and construction. The investigation, carried out by Griffiths in the mid to late 1980's, consisted of a large number of racking tests, the results of which were then used to provide an empirical basis for the British Standard design method, *BS 5268- Part 6.1* (5). The standard provided a method of calculation based upon a series of datum racking resistance values for 2.4x2.4m wall panels sheathing with commonly specified construction materials.

The value pertaining to the proposed sheathing material (1.68kN/m in the case of Orientated Strand Board, 0.9kN/m for bitumen impregnated fibreboard etc.) is subjected to a series of modification factors which alter its value based upon empirically derived relationships. For example, the datum values were derived using 3mm dia. sheathing fasteners, the modification factor for nail diameter, K_{101} , increases/decreases the racking value based upon the relative diameter of the fastener to be specified. The same approach is also used in the case of sheathing thickness, nail spacing, wall dimensions and contributions from imposed loading. The reduction to racking strength due to openings is proportional to their size expressed as a percentage of the panels overall area. Due to the low stiffness to strength ratio of timber, deflection rather than strength will often be the governing design criteria. As a result incorporated within the *BS5268-Part 6.1* design method is a design limitation to ensure that the displacement of the wall head remains within an acceptable limit of 0.003xwall height (typically 7.2mm for a 2.4m wall). *BS 5268-Part 6.1* has been successfully utilised for over 20 years. However, the introduction of Ec5 has highlighted the following shortcomings:

- i) It is not compatible with a Limit State design approach.
- ii) The data which forms its empirical base has been derived using outdated materials and construction methods.

As a result, much work is currently being undertaken in order to derive an analytically based method which is both compatible with Limit State Design and is compatible with UK methods of construction. The current draft of Ec5 contains two methods for the determination of racking strength known as Method A and Method B. Method B is a poorly executed conversion of the highlighted British Standard design method and it is widely agreed that it is inaccurate (6). Method A (the approach adopted throughout mainland Europe) is based upon the simplified plastic model for design of partially anchored wood-framed shear walls developed by Källsner et al. This method allows racking strength to be determined through an analytical approach based upon the shear capacity of the fasteners used to secure the sheathing to the timber frame in combination with the conditions of overturning restraint. The primary aim of this paper is to assess the applicability of this approach as a basis for a successful UK design method.

2.1 Basis of the Lower bound plastic model

Moy (7) gives the basis of Lower bound theory as follows: "If a set of internal forces is identified which is in equilibrium with the applied load on a structure and the yield criterion is in anyway exceeded, then the corresponding applied load is less than or equal to the collapse load". In the case of a timber frame wall panel resisting in plane loading through diaphragm action, Källsner et al. assume a simplified force distribution based upon plastic shear flow around the sheathing perimeter – see Figure 1.

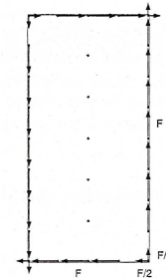

Figure 1: Force distribution on sheet – plastic lower bound model

The following assumptions must be realised for the simplified model to work successfully;

- i) The bottom runner of the shear wall must be fully anchored;
- ii) Framing members are assumed to be infinitely stiff and act in a pin jointed fashion, the effect of stud bending is not accounted for;
- iii) Sheathing material is assumed as fully rigid, the effect of shear deformation is not taken into account;
- iv) Load displacement relationship of the sheathing to frame fasteners is assumed as perfectly plastic;
- v) Full shear transfer is assumed between adjacent sheathings.

By ensuring that the conditions of force and moment equilibrium are met, the racking capacity can be estimated based upon the hold down condition of the leading stud. The procedure is highlighted for varying hold down conditions in the following sections.

2.1.1 Full restraint against overturning

In order to ensure that the leading stud is fully restrained and the panel is prevented from overturning the conditions of Eqn.1 must be fulfilled:

$$F \cdot H \leq R \cdot L \quad (\text{Eqn.1})$$

Where; F = applied racking force, H = wall panel height, R = restraint force acting upon the lead stud and L = wall panel length.

When this condition is met, the panel is assumed to behave as illustrated by Figure 2. Therefore, the racking capacity of the panel is calculated in accordance with Eqn.2.

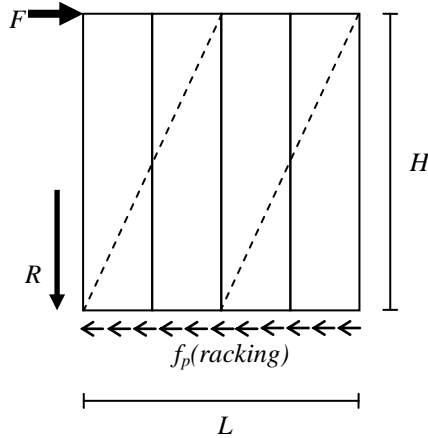

Figure 2: Analysis of fully restrained panel

$$F = f_p \cdot L \quad (\text{Eqn.2})$$

where: $f_p = \frac{f}{n_{sp}}$ with the value given in kN/m, f = shear capacity of an individual sheathing fastener and n_{sp} = spacing of perimeter sheathing fasteners

2.1.2 No restraint against overturning

In situations where the lead stud is not restrained against uplift, a portion of the sheathing fasteners along the bottom rail will be utilised in preventing the panel from overturning. In reality, these fasteners will be subjected to a vertical and horizontal shear component, although, in order to simplify the analysis it is assumed that they are subjected to either a horizontal or vertical component but not both in combination. The utilisation of fasteners in the resistance of overturning forces means that a lower percentage of fasteners are available for “racking duties”. As a result the calculated racking strength is decreased – see Figure 3

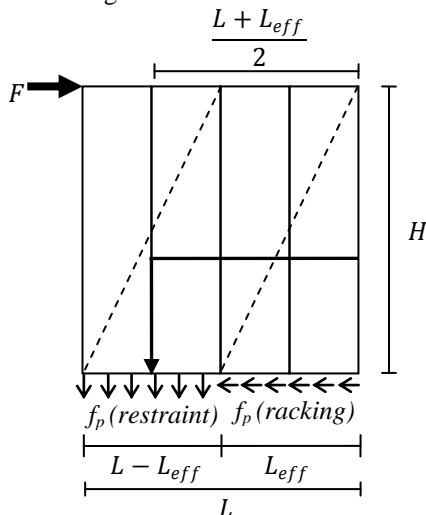

Figure 3: Analysis of non restrained panel

The effective length (L_{eff}) of the bottom rail which provides racking resistance can be determined by ensuring that the conditions of moment equilibrium – as given in Eqn.3 are fulfilled:

$$F \cdot H = f_p (L - L_{eff}) \left(\frac{L + L_{eff}}{2} \right) \quad (\text{Eqn.3})$$

Alternatively, the effective length can be calculated as per Eqn.4.

$$l_{eff} = l \left[\sqrt{1 + \left(\frac{1}{\alpha} \right)^2} - \frac{1}{\alpha} \right] \quad (\text{Eqn.4})$$

where: α = dimensionless panel ratio $\frac{l}{h}$

In situations where the panel ratio is equal to 1, the racking capacity will be equal to approximately 41% of the total shear capacity of the sheathing to bottom runner fasteners. Where the panel ratio equals 0.5 this is reduced to approximately 24%. The racking strength of the panel is calculated in accordance with Eqn.5:

$$F = f_p \cdot L_{eff} \quad (\text{Eqn.5})$$

2.1.3 Partial restraint against overturning

In the case of a panel which is partially restrained against overturning, the hold down force acting upon the lead stud is taken into account when determining the equilibrium of the panel as shown in Figure 4

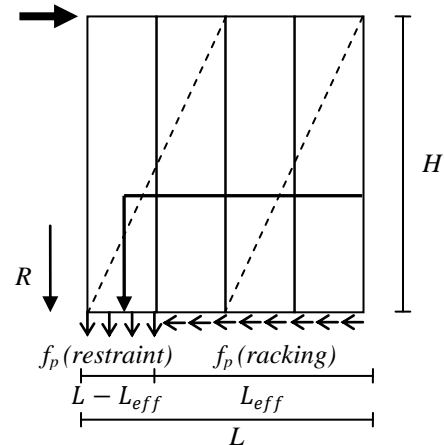

Figure 4: Analysis of a partially restrained panel

Again, the effective length of the bottom rail which resists racking forces is calculated according to moment equilibrium, this time, the restoring moment from the hold down force is also taken into account resulting in Eqn.6.

$$F \cdot H = f_p (L - L_{eff}) \left(\frac{L + L_{eff}}{2} \right) + R \cdot L \quad (\text{Eqn.6})$$

Dependent on the magnitude of the hold down force, the racking capacity of a partially restrained panel will lie somewhere between that of a fully and a non-restrained panel. The capacity of such a panel can be calculated by using Eqn.6 to determine L_{eff} and then using that value in Eqn.5.

2.2 Calculation of panel stiffness

As previously stated, when considering timber frame structures, ensuring that the limits set for deflection are not breached will, in most cases, be the overriding

design consideration. In cases where several wall panels are placed next to each other, it is unlikely that this will be a significant problem. However, since house designs in the UK are typified by short length full height wall sections acting in isolation e.g. wall sections adjacent to large patio doors and windows, an accurate method of determining the deflection at the wall head is required.

2.2.1 Determination of panel stiffness according to a linear elastic model

By assuming that when a wall panel is subjected to a racking load, the frame distorts as a parallelogram, a linear elastic model can be applied to the behaviour of the sheathing fasteners – see Figure 5 Note – full restraint of the leading stud has been assumed in this case.

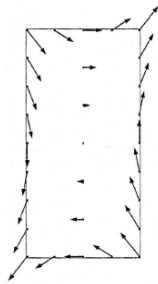

Figure 5 Force distribution on sheet according to linear elastic model

The assumed distribution allows the force acting upon each individual fastener to be estimated based upon the applied racking load. By taking the centre of the panel as the centre of rotation, the forces acting upon an individual fastener can be calculated based upon its relative location. The horizontal (f_{xi}) and vertical (f_{yi}) component can be determined as per Eqn.7:

$$f_{xi} = \frac{F \cdot h \cdot y_i}{\sum y_i^2} \quad (\text{Eqn.7a})$$

$$f_{yi} = \frac{F \cdot h \cdot x_i}{\sum x_i^2} \quad (\text{Eqn.7b})$$

where: h = height of the sheathing and x_p, y_i = x and y coordinates for an actual fastener.

The actual force is simply determined by resolving the two component forces as per Eqn.8:

$$f_i = \sqrt{f_{xi}^2 + f_{yi}^2} \quad (\text{Eqn.8})$$

The greatest force will always occur at the fastener furthest from the centre of rotation i.e. those located at the corner. If the shear capacity of this fastener is known, then it can be used to determine the overall racking capacity of the wall panel. This method of calculation has been shown to provide results of good correlation to that of the simplified plastic model as described in Section 2.1.

When a stiffness value (k) is known for the sheathing-to-frame connection then this can be used to calculate the deflection at the wall head due to nail slip Δ_n using Eqn. 9

$$\Delta_n = \frac{F \cdot h^2}{k} \left(\frac{1}{\sum_{i=1}^n x_i^2} + \frac{1}{\sum_{i=1}^n y_i^2} \right) \quad (\text{Eqn.9})$$

The deflection arising as a result of shear deformation of the sheathing material can be estimated by treating the sheathing as a cantilever beam with a point load at the top – see Eqn.10. Due to the fact the assumed beam is of relatively great depth (span/depth ratio < 3), it is necessary to apply a form factor when calculating deflection due to shear. For a rectangular section this is given as $\frac{6}{5}$ (9)

$$\Delta_s = \frac{6}{5} \cdot \frac{F \cdot h}{N \cdot G \cdot t \cdot l} \quad (\text{Eqn.10})$$

Where: N = number of panels, G = shear modulus of the sheathing material, t = thickness of sheathing material and l is the sheathing length.

The total panel deflection can therefore be simply estimated from the summation of the nail slip and shear deformation.

3 Methods

A series of tests were undertaken in order to determine the strength and stiffness properties of the following:

- i) A range of full scale shear wall panels utilizing differing sheathing arrangements, nail spacing's and hold down conditions.
- ii) The connection of the sheathing material to the frame.

3.1 Racking tests

A series of 20 wall panels were manufactured and tested in accordance with *BS EN 594:1996*.

3.1.1 Panel details

Panels were manufactured using 38×140mm C16 grade timbers for the framing members. Each vertical stud was affixed to the top and bottom runner using 3.1×90mm helically threaded fasteners (3no. per connection). The frame was sheathed using 9mm OSB/3 secured to the frame with 2.85×50mm galvanised smooth wire fasteners. The position of these fasteners was measured out and marked prior to fabrication in order to ensure accurate spacing's were maintained. Fastener spacing on internal studs was twice that used around the sheathing perimeter. In keeping with current UK practice, an expansion gap of approximately 5mm was left between abutting sheathing sections.

The average densities of the timber and OSB used in the program were determined to be 436kg/m³ and 614kg/m³ respectively. Unless otherwise specified, panels were tested with only one side sheathed. Details of each panel are given in Table 1.

Table 1: Details of wall panel manufacture

Panel type	Dimensions (m)	Nail spacing (mm)	Stud spacing (mm)	Sheathing Layout
A	2.4×2.4	150/300	600	2no. 1.2×2.4m
B & Bv	2.4×2.4	150	300	8no 0.3×2.4m
C & Cr	2.4×2.4	75/150	600	2no. 1.2×2.4m
D & Dr	2.4×2.4	50/100	600	2no. 1.2×2.4m
E & Er	2.4×2.4	50/100	600	4no. 1.2×2.4m
F & Fr	1.2×2.4	75/150	600	1no. 1.2×2.4m

Note: Nail spacing of 150/300 denotes 150mm c/c around perimeter and 300mm c/c internally et sec.
In all case sheathing was orientated running parallel to the studs

3.1.2 Racking test method

Racking tests were carried out on a purpose built racking test rig. The panel was affixed to the test rig using 4no. M20 type bolts. The lead bolt was positioned 150mm from the leading edge with subsequent bolts spaced at 600mm centres. The racking load was supplied via a single 15 Ton capacity hydraulic ram. In cases where a vertically imposed load was applied (panel type. Bv), this was provided by 5no. 1 Ton capacity rams acting over every second stud with each ram providing a 4.8kN load (approximately equivalent to 10kN/m). Each ram was connected to a load cell in order to accurately record the load as it was applied. The end of each ram was fitted with a roller joint in order to ensure that the deflection of the panel was in no way impeded. Where the rams contacted the panel, a thin steel plate was affixed in order to ensure that embedment did not occur. Details of the panel test rig and hydraulic racking ram are shown in Figure 6.

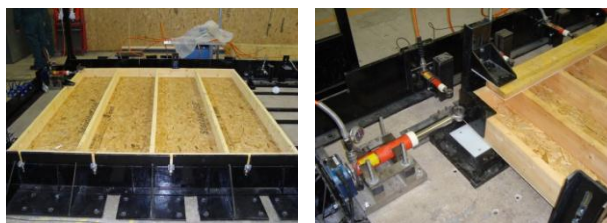
**Figure 6: Racking test rig and hydraulic ram detail**

Due to the fact that 140mm wide timbers were used in panel construction, the method used to secure the bottom runner of the panel to the test frame was over specified in order to ensure that transverse bending of the member did not occur. 130mm square washers fabricated from 5mm thick steel plate acted between the nut and bottom rail and the nut and the outer edge of the test rig. Panels *Er* & *E* were “double sheathed” i.e a single layer of sheathing was applied to each face. This was accomplished by securing the single sheathed panel to the frame and then affixing the secondary sheathing in situ.

4 of the panel types (*Cr*, *Dr*, *Er* and *Fr*) were tested with the leading stud fully restrained by a hold down strap. This was specifically manufactured for the purpose and was secured to the face of the lead stud using 51no. 2.85×50mm long nails and to the test frame with 2no.

M20 bolts. Details of the method used to affix the panel to the test frame and of the hold down strap are shown in Figure 7.

**Figure 7: Method of securing the panel to the test rig (l) and detail restraint strap providing resistance to overturning forces (r).**

Loading was applied in accordance with the test standard – see

Figure 8 for details

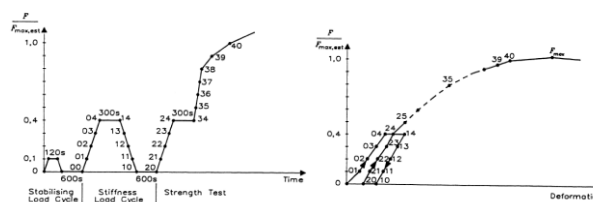
**Figure 8 Details of BS EN 594:1996 loading schedule adopted throughout test program**

Displacement transducers were set up in order to measure the horizontal and vertical movement of the panel. Data from both the transducers and the load cells was recorded at 1 second intervals.

3.2 Shear capacity of fastener

As demonstrated in Section 2 the shear capacity of the fastener used to affix the sheathing material to the frame is critical in determining the overall racking capacity of the wall panel. Whilst the strength and stiffness properties of this connection can be approximated through calculation, in order to correctly assess the applicability of the simplified plastic model the inputted values must reflect those actually attainable in practice. For this reason, fastener shear capacity was determined through test.

3.2.1 Connection detail

The tested connection comprised of 9mm OSB sheathing connected to the narrow edge of a 38×140mm timber baton. The materials used were taken from the tested wall panels and therefore the material properties were identical to those used during the racking tests. Fasteners were Paslode 2.85×50mm galvanised smooth wire nails with a test determined tensile strength of 911N/mm².

3.2.2 Connection test method

The test set up was design to best replicate the forces acting on a sheathing fastener when forming part of an actual wall panel. In order to determine both the strength and stiffness of the connection, loading was applied in accordance with BS EN 26891:1991(10) - estimated maximum load, $f_{est} = 2200N$, rate of loading 1.5mm/min. In order to avoid a concentration of stresses, the load was applied to the OSB material below the position of the fastener - as shown in Figure 9. A total of 10 tests were undertaken to satisfy the needs of this preliminary investigation. In order to achieve a characteristic value for design publication purposes a more extensive program of work is required.

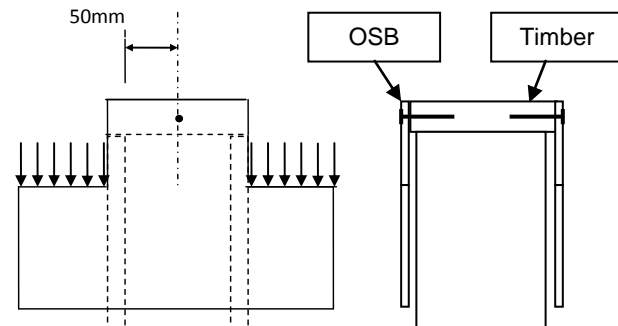

Figure 9 Test set up used in the determination of sheathing fastener shear capacity.

4 Results

The results of both the racking tests and the fastener tests are given in the following sections.

4.1 Results of racking tests

The strength and stiffness values for the tested wall panels detailed in Section 3.1.1 are given in Table 2

Table 2 Strength and stiffness determined in accordance with BS EN 594:1996. Results taken as average of 2 tests.

Panel type	Ultimate strength - kN (F_{max})	Deflection at $0.4F_{max}$ -mm
A	12.26	6.76
B	11.66	9.79
Bv	15.54	10.43
C	19.54	8.40
Cr	36.14	12.31
D	24.79	10.84
Dr	49.37	15.95
Er	>82.48	13.33
E	39.12	8.15
F	4.31	12.83
Fr	17.03	26.48

Illustrations of the panel failures are given in Figure 10. With the exception of the panels highlighted, failure occurred in a ductile fashion with the lead stud observed to pull away from the bottom runner. The

sheathing fasteners along the bottom runner “unzipped” as F_{max} was approached – see Figure 10 i)-iii). In all cases, some bending of the stud members was observed. Exceptions to this type of failure are given as follows:

Panel type *Bv*: resistance to the application of the racking load began to decrease at approximately 14kN although began to pick up again as F_{max} was approached. Panel type *Cr*: frame deflected relative to sheathing due to out of plane sheathing buckling (

Figure 10 iv & v). Significant deflection of lead stud was noted as F_{max} was approached. Buckling and twisting of trailing stud under compressive loading was also observed

Panel type *Dr*: separation of sheathing from frame due to sheathing buckling. Framing fasteners connecting the top runner to each stud were observed to break through the stud face (

Figure 10 vi). Failure at F_{max} was sudden/ brittle in nature due to sheathing separating from frame completely.

Panel type *Er* – provided resistance throughout test. Premature failure due to breaching of test equipment safe working load therefore $F_{max} > 82.48kN$

Panel type *E* – ductile failure. Even with over specified washers used to secure the bottom rail it was noted that some spitting due to transverse forces occurred.

Panel type *Fr* – significant deflection of sheathing relative to frame with buckling notes at top of leading stud. Bending and twisting of trailing stud due to compressive loading.

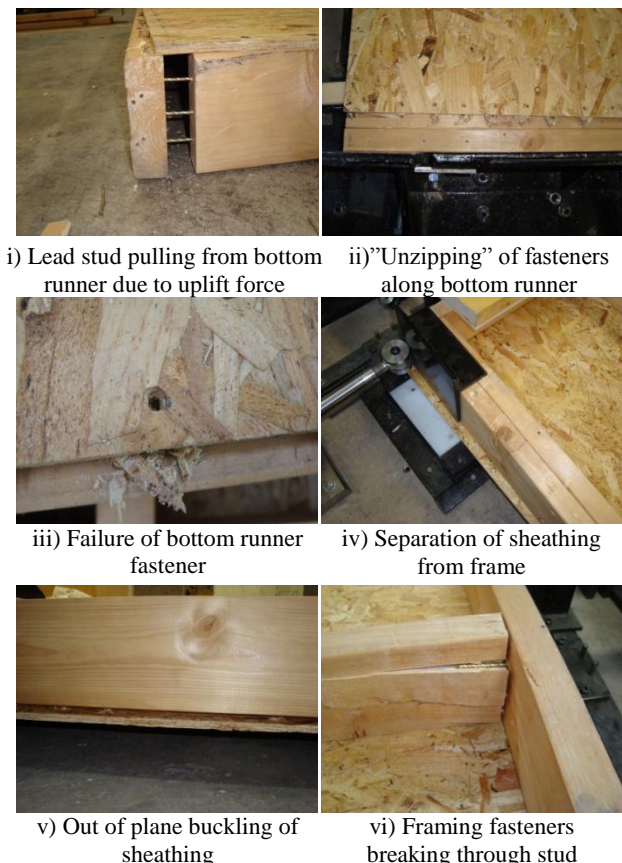

Figure 10 Example of racking failures

4.2 Results of fastener tests

The strength and stiffness of the OSB-to-timber connection detailed in Section 3.2.1 is given in Table 3.

Table 3 Results of connection test

Connection detail	Ultimate strength - N (f_{max})	Stiffness - N/mm (k)
OSB-to-Timber connected with 2.85x50mm SWN	1075	932

Note - results taken as the average of 10 tests

5 Discussion

The results of the test program are discussed in relation to the highlighted method for calculating strength and stiffness.

5.1 Accuracy of strength calculation

The strength of the tested panels is calculated based upon the methods detailed in Section 2. In each case the value of f_p is based upon the nail spacing used for the respective panel and the value of f_{max} given in Table 3. Values calculated in accordance with the above are presented in Table 4.

Panel type.	f_p - kN/m	Effective length - L_{eff}	Racking strength - kN
A	7.17	0.99m	7.10
B	7.17	0.99m	7.10
Bv	7.17	0.99m	7.10
C	14.3	0.99m	14.16
Cr	14.3	2.40m	34.32
D	21.5	0.99m	21.29
Dr	21.5	2.40m	51.6
Er	43	2.40m	103.2
E	43	0.99m	42.57
F	14.3	0.28m	4.00
Fr	14.3	1.2m	17.16

Table 4 Racking strength calculated as per simplified plastic theory.

As an aid to comparison, calculated values are plotted against values from test (Figure 11). Comparing the actual and calculated strength results relative to one another reveals a good degree of correlation. The notable exception to the rule is Panel type *Er*, however, it should be remembered that due to the equipment limitations the test was stopped before F_{max} was reached.

Based upon the values used, the simplified plastic model generally provides conservative results. In the case of high performance panels (dense nailed, double and/or overturning is prevented) it would appear that the method suggests marginally higher strength values than are actually achievable.

The reasons for this overestimation may be due to the assumed panel behaviour. According to the model, a panel fails when a sheathing fastener reaches its ultimate strength (f_{max}). The observed failure modes of the tested panels would suggest that it is necessary to set an

upper limit based upon the out of plane buckling behaviour of the sheathing.

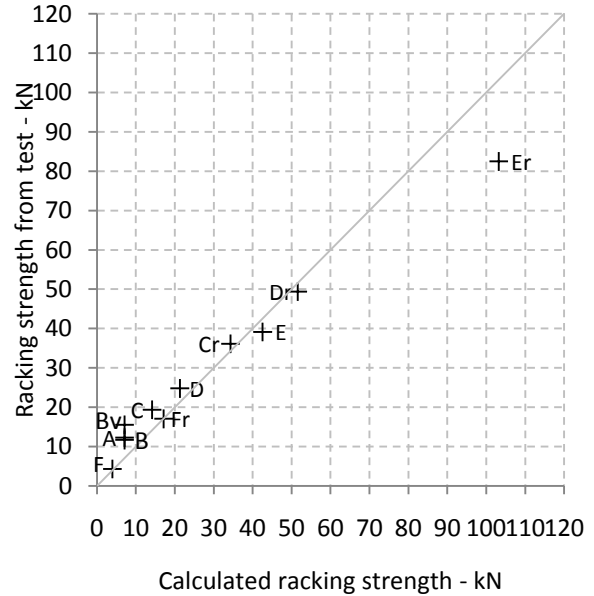

Figure 11 Comparison between calculated racking strength and values derived from test

5.2 Panel stiffness

In accordance with limit State Design theory, it should be ensured that neither the Ultimate Limit State (relating to F_{max}) or the Serviced Limit State (relating to panel deflection) are breached. In practice, structures should be designed to ensure that no part ever goes through an irreversible plastic deformation. For this reason, the ultimate panel strength should not be used as design without ensuring that the resulting deflection will be within the allowable limit. By doing so, it will be ensured that the Service Limit State is not breached.

5.2.1 Accuracy of stiffness calculation

The stiffness of the tested panels is calculated based upon the method highlighted in Section 2. In each case the stiffness value, k , derived from the connections tests has been used. In the calculation of the deflection due to shear deformation, the shear modulus of OSB/3 has been taken as 1080N/mm². Calculated deflections at $0.4F_{max}$ are given in Table 5. Due to the fact that the method does not account for the effect of vertical imposed loading, calculations for panel type *Bv* have been omitted. Calculated deflection for panels are shown plotted against the measured test deflection at $0.4F_{max}$ in Figure 12

The comparison clearly shows that calculating a wall panel's deflection based solely upon nail slip and shear deformation of the sheathing material leads to an overestimated stiffness value. It is clear that there are additional elements relating to panel stiffness behaviour that need to be considered. These include, but are not limited to the following:

Displacement of the leading stud due to uplift forces. In practice, this will occur even if a hold down strap/tie is used due to its elongation under load and/or nail hole

tolerances. Stud uplift will cause an alteration to the panels centre of rotation which in turn will affect the sheathing fastener behaviour.

Table 5 Calculated deflection at $0.4F_{max}$

Panel type	Deflection due to nail slip –mm (Δ_n)	Deflection due to sheathing deformation – mm (Δ_s)	Total deflection – mm ($\Sigma \Delta$)
A	1.15	0.50	1.65
B	4.19	1.98	6.17
Bv	-	-	-
C	0.86	0.73	1.59
Cr	2.02	1.74	3.76
D	1.00	1.29	2.30
Dr	1.73	2.22	3.95
Er	1.63	2.10	3.74
E	0.87	1.12	1.98
F	0.58	0.25	0.82
Fr	2.08	0.89	2.98

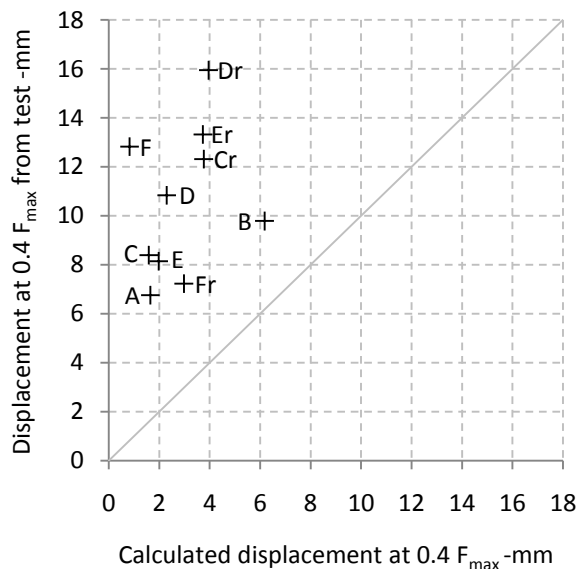

Figure 12 Comparison between calculated racking deflection at $0.4 F_{max}$ and the measured deflection from test

Rigidity of the framing material. The method demonstrated here assumes that framing members are infinitely stiff i.e able to transfer forces perpendicular to their major axis. In reality, there will be a degree of flexibility, and this must be taken into account in order to ensure accuracy.

Influence of expansion gaps. It is normal practice to install sheathing with at least a 5mm gap between. As the sheathing displaces, this gap will close and when sheathing members butt against each other there will be a change to the stiffness behaviour.

Non linear fastener nail slip relationship. Fastener load/slip curves are characterised by highly non linear load/slip relationships. If the entire racking behavioural curve is to be plotted this must be taken into account in

order to accurately calculate the deflection due to nail slip with an increasing load

Tolerances within the panel construction. During racking test, it was noted that every panel exhibited an increased stiffness during the secondary loading phase as a result of the first phase test allowing bedding in to take place.

Method of securing the panel's bottom runner. In practice, the stiffness behaviour of the bottom runner-to-soleplate and the soleplate-to-substrate will have an effect on the deflection at the wall head.

6 Conclusion

Based upon the findings reported, it is concluded that the simplified plastic model for the design of shear wall appraised here is suitable for the strength determination of imperforate walls subjected to a variety of restraint conditions.

The accuracy of the method when assessing double sheathed fully restrained panels with dense nailing patterns (eg. Panel type “Er”) requires to be confirmed through further testing. However, initial results presented here-in suggest that the method could also be applied to this type of very high performance wall panel. For practical design purposes it may be necessary to specify an upper strength limit based upon the buckling strength of the sheathing material.

This said, stiffness will in the majority of cases be the limiting criteria. The stiffness calculation method reviewed in this paper is based on nail slip and shear deformation of the sheathing and does not provide the level of accuracy required especially when considering standard UK panel fabrication practice. As a result a more holistic design approach is required, that more rigorously considers the complex interaction of the component parts of a timber frame shear wall.

Acknowledgements

The author would like to thank the Royal Academy of Engineering for their assistance in attending the conference.

References

1. **British Standards Institution.** BS EN 1995-1-1:2004+A1:2008. *Eurocode 5: Design of timber structures —Part 1-1: General — Common rules and rules for buildings.* London : BSI, 2009. Includes CEN ammendment A1. ISBN 978 0 580 65467 1.
2. —. BS EN 594:1996. *Timber Structures - Test methods - Racking strength and stiffness of timber frame wall panels.* London : BSI, 1996. ISBN 0 580 25724.
3. *A simplified plastic model for the design of partially anchored shear walls.* **Källsner, B and Girhammar, U A.** Venice : Universitat Karlsruhe, 2001. Working Commission W 18 - Timber structures (CIB-W18).
4. **Griffiths, D R.** *The racking performance of Timber Frame Walls assessed by experimental and analytical techniques- PhD Thesis.* s.l. : University of Surrey, 1987.
5. **British Standards Institution.** BS 5268-6.1:1996. *Structural use of timber - Part 6: Code of practice for*

timber frame walls - Section 6.1 Dwellings not exceeding four stories. London : BSI, 1998. ISBN 0 580 24969 7.

6. **J. Porteous, A. Kermani.** *Structural Timber Design to Eurocode 5.* Oxford : Blackwell Science Ltd, 2007. ISBN 978-14051-4638-8.

7. **Moy, S. S.J.** *Plastic methods for steel and concrete structures.* 2nd revised edition. s.l. : Palgrave Macmillian, 1996. ISBN-10: 0333641779.

8. *Racking deformations in wood shear walls.* **McCutcheon, W J.** 2, 1985, Journal of Structural Engineering, Vol. 111, pp. 257-269.

9. **Young, W C and Budynas, R G.** *Roark's Formulas for stress and strain.* 7th Edition. s.l. : McGraw-Hill, 2002. ISBN 0-07-072542-X.

10. **British Standards Institution.** BS EN 26891:1991/ISO 6891:1983. *Timber Structures - Joints made with mechanical fasteners- General principles for the determination of strength and deformation characteristics.* London : BSI, 2000. ISBN 0 580 19856 1.